

SERVICE NOTES

TUNER AMPLIFIER

5911/03/04

5912/03/04

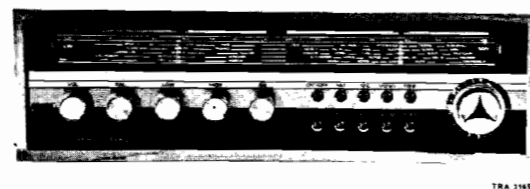
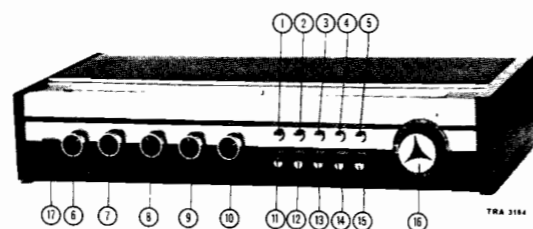

- ① Mains switch SK-B
Netschakelaar
- ② Aerial switch SK-A
Antenne schak.
- ③ AFC switch SK-D
AFC-schak.
- ④ Mono/stereo switch SK-E
Mono/stereo-schak.
- ⑤ Tone switch SK-H
Toon-schak.
- ⑥ Volume control R65/115
Volumeregelaar

- ⑦ Balance control R68/118
Balansregelaar
- ⑧ Bass control R74/124
Lagetonen-regelaar
- ⑨ Treble control R77/127
Hogetonen-regelaar
- ⑩ Tuning AM C11/12
Afstemming AM
- ⑪ LW switch SK-L
LG-schakelaar

- ⑫ MW switch SK-M
MG-schak.
- ⑬ FM switch SK-F
FM-schak.
- ⑭ Rec.-player switch SK-G
PU-schakelaar
- ⑮ Recorder switch SK-T
Magn.-schak.
- ⑯ Tuning FM S39÷41
Afstemming FM
- ⑰ FM stereo-indicator LA 4
FM stereo-indikator

IF - AM
IF - FM
Mains voltages
Consumption
Output power
Output impedance
Loudspeaker box
with loudspeaker (4 Ω)
Dimensions 5911/03/04
5912/03/04
LW
MW
FM

452 kHz
10.7 MHz
110-127-220-240 V~
54 mA - 8 W (220 V~)
2x8 W (5 Ω)
4 Ω - 8 Ω
Lz4 = 4 Ω
4822 240 20065 (0-4654Y)
470x80x225 mm
470x130x225 mm
2000x1071 m (150-280 kHz)
579.1-185.2 m (518-1620 kHz)
87.5 - 100 MHz

MF - AM
MF - FM
Netspanningen
Verbruik
Uitgangsvermogen
Uitgangsimpedantie
Luidsprekerbox
met luidspreker (4 Ω)
Afmetingen 5911/03/04
5912/03/04
LG
MG
FM

Transistors, diodes

T1 - BF195
T2 - BF195
T3 - BF195
T4 - BF194
T5 - BF194
T6 - BF194
T7, 14 - BC108
T8, 15 - BC109
T9, 16 - BC109
T10, 17 - AC126
T11, 18 - AD161
T12, 19 - AD161/162
T13, 20 - AD161/162

T401 - BC148
T402 - BC148
T403 - BC148
T404 - BC148
T405 - BC148
T406 - AC128
X1 - BA102
X2 - AA119
X3 - AA119
X4, 5 - 2-AA119
X6, 7, 8, 9 - B40C2200
X407 - AA119

X408 - AA119
X409 - AA119
X410 - AA119
X411 - AA119
X412 - AA119
X413 - BA100

Cabinet 5911/03 teak
Cabinet 5911/04 palisander
Cabinet 5912/03 teak
Cabinet 5912/04 palisander
Foot black
Foot brown
Front panel without lens 5911/03/04
Front panel without lens 5912/03/04
Lens (green)
FM speed tuning unit

4822 425 50059
4822 425 50063
4822 425 50061
4822 425 50062
4822 462 70505
4822 462 70529
4822 454 10151
4822 454 10157
4822 381 10222
4822 691 10059

Kast 5911/03 teak
Kast 5911/04 palisander
Kast 5912/03 teak
Kast 5912/04 palisander
Voet zwart
Voet bruin
Frontplaat zonder lens 5911/03/04
Frontplaat zonder lens 5912/03/04
Lens (groen)
FM-afstemunit met voor-instelling

Fuse holder
Knob tuning (FM)
Knob
Push-button
Push-button unit (wave range)

4822 256 30097
4822 413 50638
4822 413 40367
4822 410 10016
4822 276 50153

Smeltveiligheids houder
Knop afstemming (FM)
Knob
Druktoets
Druktoetseenheid (golfgebied)

Push-button unit + mains switch
Plug aerial FM
Plug aerial AM
Socket (5 pole)
Plug (5 pole)

4822 276 50154
4822 264 30043
4822 264 30042
4822 267 40039
4822 264 40023

Druktoetseenheid (netschakelaar)
Steker antenne FM
Steker antenne AM
Aansluiting (5 polig)
Steker (5 polig)

Socket (7 pole)
Socket LS
Plug LS
Drum on variable capacitor
Pulley (small)

4822 267 50101
4822 267 40073
4822 264 30041
4822 528 40147
4822 528 80051

Aansluiting (7 polig)
Aansluiting LS
Steker LS
Trommel op var. condensator
Snaarwiel (klein)

Pulley (large)
Pointer 5911/03/04
Pointer 5912/03/04
Drive cord
Tuning spindle AM

4822 528 40106
4822 450 80221
4822 450 80224
4822 321 30102
4822 528 40146

Snaarwiel (groot)
Wijzer 5911/03/04
Wijzer 5912/03/04
Aandrijfsnaar
Afstemas AM

Stop-pin of AM-spindle
Core of coil S39, 40
Core of coil S41
Detection unit
Stereo decoder

4822 535 90523
4822 526 10076
4822 526 10077
4822 210 20145
4822 210 30015

Stop-pen op AM-afstemas
Kern van spoel S39, 40
Kern van spoel S41
Detectie-unit
Stereo decoder

Scale 5911/03/04
Scale 5912/03/04
Fuse 1,25 A Z1, 2
Fuse Z3
Dial lamp LA1, 2, 3
Indication lamp LA4

4822 334 60014
4822 334 60015
4822 253 20019
4822 252 20001
4822 134 40054
4822 134 40003

Schaal 5911/03/04
Schaal 5912/03/04
Zekering 1,25 A Z1, 2
Zekering Z3
Schaallamp LA1, 2, 3
Indikatielamp LA4

Oscillator coil MW-LW
Ferroceptor MW-LW
Aerial coil MW
Aerial coil LW
IF coil AM+FM

S1, 2, 3
S4 - 7
S8 - 10
S11 - 13
S14 - 17, C20

4822 156 30264
4822 158 60234
4822 156 30178
4822 156 10316
4822 153 90022

Oscillatorspoel MG-LG
Ferroceptor MG-LG
Antennespoel MG
Antennespoel LG
MF-spoel AM+FM

IF coil FM
IF band pass filter AM
Mains transformer
Aerial coil FM
Absorption coil FM

S18, 19, C25
S20 - 22
S30-35, Z3
S36 - 38
S42

4822 153 90023
4822 156 30185
4822 146 40161
4822 158 10017
4822 158 10138

MF-spoel FM
MF-bandfilter AM
Nettransformator
Antennespoel FM
Zuigkringspoel FM

Rejection coil AM
IF band pass filter AM

S50
S44 - 46, C66

4822 156 20025
4822 153 90009

Sperkringspoel AM
MF-bandfilter FM

C2, 3, 5, 7
C4
C8, 10
C9
C11, 12
C14, 76, 101
C19
C24

4822 125 50018
4822 121 50048
4822 125 50017
4822 121 50039
4822 125 20089
4822 121 50094
4822 121 50088
4822 121 50188

4822 121 50053
4822 124 20116
4822 124 70012
4822 125 50026
4822 121 50083
4822 121 40096
4822 125 20028
4822 121 50067

R10, 11
R68, 118
R74, 77, 124, 127
R91, 141
R92, 142
R97, 98, 147, 148
R65, 115
4822 116 20063
4822 102 30113
4822 102 30086
4822 116 60002
4822 116 30057
4822 116 50182
4822 102 30044 +
4822 535 90226

Stereo decoder

1^e 19 kHz coil
2^e 19 kHz coil
Detector coil

S414
S415
S416

4822 156 70031
4822 156 50016
4822 156 30275

1^e 19 kHz-spoel
2^e 19 kHz-spoel
Detectorspoel

Index: CS13320-CS13325

SERVICE INFORMATION									
---------------------	--	--	--	--	--	--	--	--	--

HFD/JD

Copyright reserved. Confidential information for Service Dealers.

4822 720.1.0232

Printed in Holland

C502, 503, 505, 506, 508, 511
C504, 515, 516
C509
C517, 518, 520

4822 121 50089
4822 121 50072
4822 124 20018
4822 121 50082

R604
R609
R613

4822 100 10025
4822 100 10021
4822 100 10026

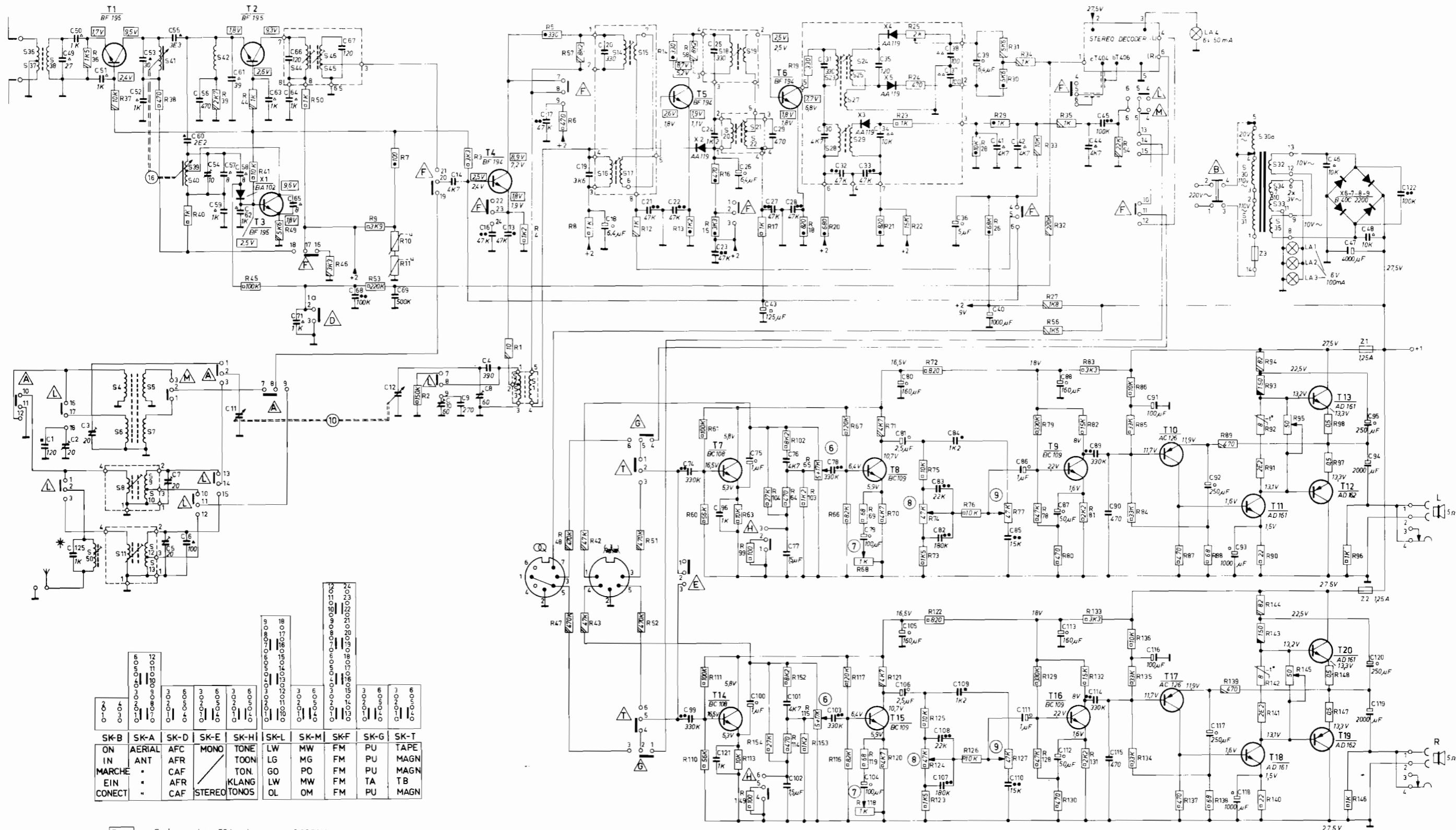

SK-B	SK-A	SK-D	SK-E	SK-H	SK-L	SK-M	SK-F	SK-G	SK-T
ON	AERIAL	AF	MONO	TO	LW	MW	FM	PU	TAPE
IN	ANT	AFR	TOON	LG	MG	FM	FM	PU	MAGN
MARCHE	CAF	CAF	TON.	GO	PO	FM	FM	PU	MAGN
EIN	CAF	CAF	KLANG	LW	MW	FM	FM	TA	TB
CONNECT	CAF	CAF	STEREO	OL	OM	FM	FM	PU	MAGN

- Carbon resistor E24 series 0.125 W 5%
- Carbon resistor E12 series 0.25 W < 1 MΩ 5% > 1 MΩ 10%
- Carbon resistor E12 series 0.5 W < 1.5 MΩ 5% > 1.5 MΩ 10%
- Carbon resistor E12 series 1 W < 2.2 MΩ 5% > 2.2 MΩ 10%
- Ceramic capacitor "Pin-up" 500 V
- Tubular ceramic capacitor 500 V
- Styroflex capacitor 500 V
- Polyester capacitor 400 V
- Flat-foil polyester capacitor
- Miniature electrolytic capacitor

The voltages have been measured with respect to the "-" (chassis) with the aid of a valve voltmeter. The voltages in squares have been measured in position FM. For a correct setting of the output transistors it is necessary to adjust the voltage across R97-R98 and R117-R148 to 15 mV by means of R95 and R145 respectively.

* This IF rejection circuit is included only in the 5911/03/04 and the 5912/03/04.

De spanningen zijn m.b.v. een huisvoltmeter t.o.v. "-" (chassis) gemeten. De onlinijnige spanningen zijn gemeten in stand FM. Voor het instellen van de eindtransistoren moet met behulp van R95 resp. R145 de spanning over R97-R98 resp. R117-R148 ingesteld worden op 15 mV.

* Deze MF-sperkring is alleen in de 5911/03/04 en de 5912/03/04 gemonteerd.

S	50,36,37,38.	41, 42, 44,45,46, 4, 5.	39,40.	20,21,22,6,7,18,19, 14,15,16,17.	1, 2, 3, 23,24,25,27, 28,29,8,9,10,11,12,13.	30, 30a, 31, 32, 33,34,35.	S
C	50,51, 49.	63, 56.	60, 65,54,58,57,68.	26, 29,23.	44,45,71,16,13,28,22, 1, 3, 6, 42,41, 8, 9.	47.	94, 89.
C	53, 55, 52,125,61, 64,40.	62, 59, 43, 69.	36, 24,18, 14,70,27,17,19, 21, 2, 5,7, 39,4, 10.				79, 87, 88, 92, 111,113, 110,95,109,93,122,108,82,104, 81, 118,115, 120,103, 100,101,74, 121,99, 102.
R	36,44,38, 39, 50, 56, 27,41, 10,11,45, 7, 17, 3, 35, 46,14, 15, 1, 34, 29, 20.						83, 80, 78,72, 88, 130, 96, 84, 126, 97,74, 98, 73,91, 69,120,122,142, 148,117, 136,104,138,135,60,102,154, 63.
R	37, 51.	52,47, 49, 40, 48, 42,43,9, 8, 6, 54, 55, 26, 13, 30,21, 28, 2.					82, 81, 128, 77,131, 85, 132,94,124,123,95, 141,70, 119,133,140,71,67,121,147,134,61,146,152,64,113,153.
R			53, 16, 33, 4, 58, 5, 57, 32, 31, 22				127, 86, 129,89, 76,90,87,93, 92, 125,68, 118,145,143,137,66,116,144,139,110,111,65,115,103,114.

T1:6

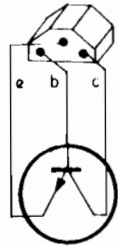

T7:9

T14:16

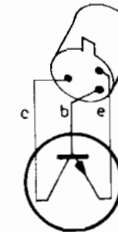

T10,17

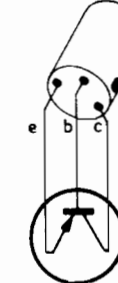

T11,13,18,20

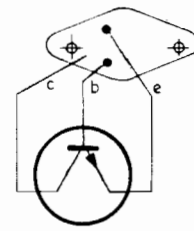

T12,19

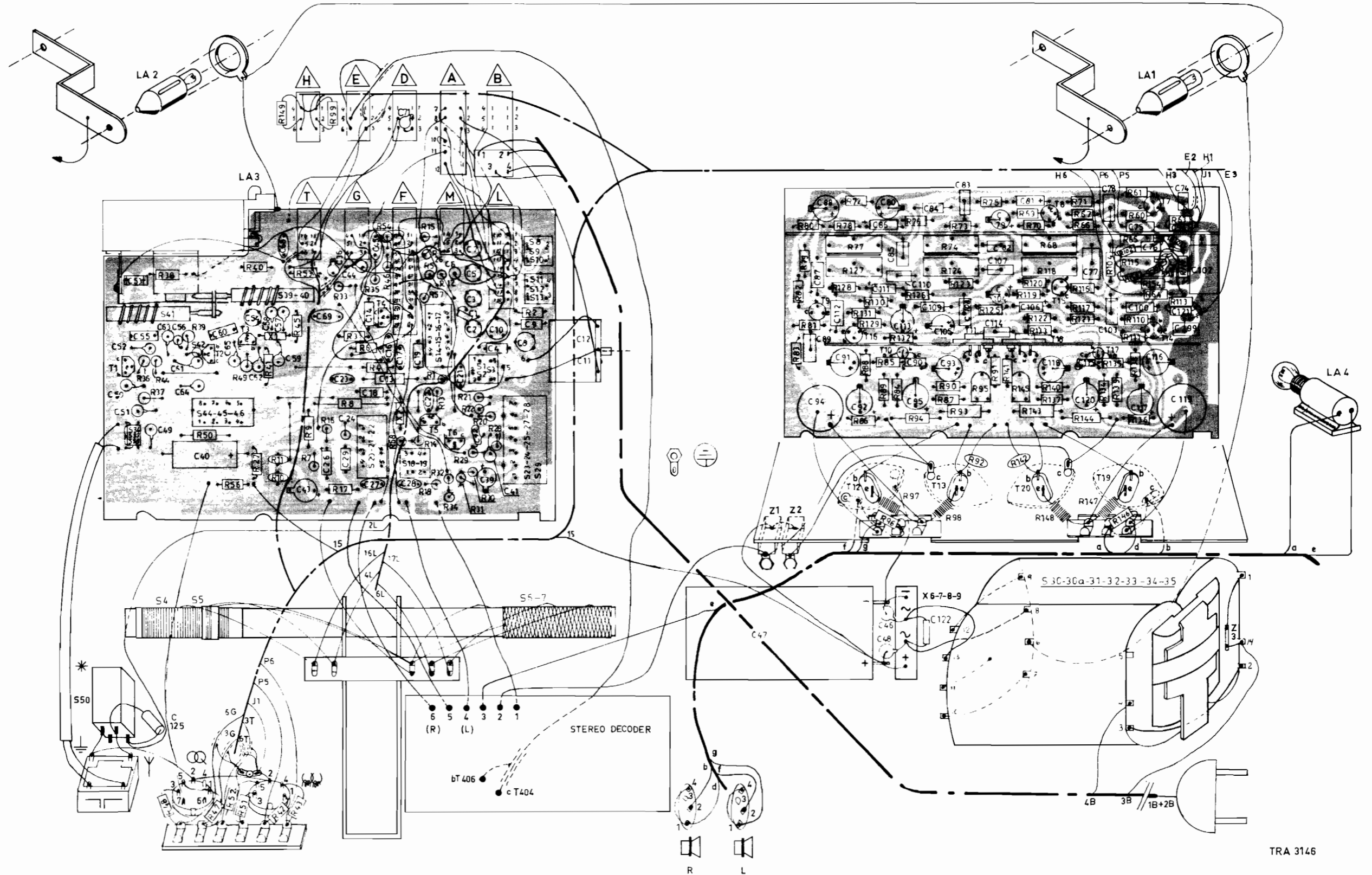
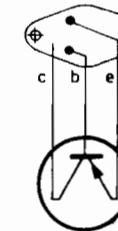

* This IF rejection circuit is included only in the 5911/03/04 and the 5912/03/04.

* Deze MF-sperkring is alleen in de 5911/03/04 en de 5912/03/04 gemonteerd.

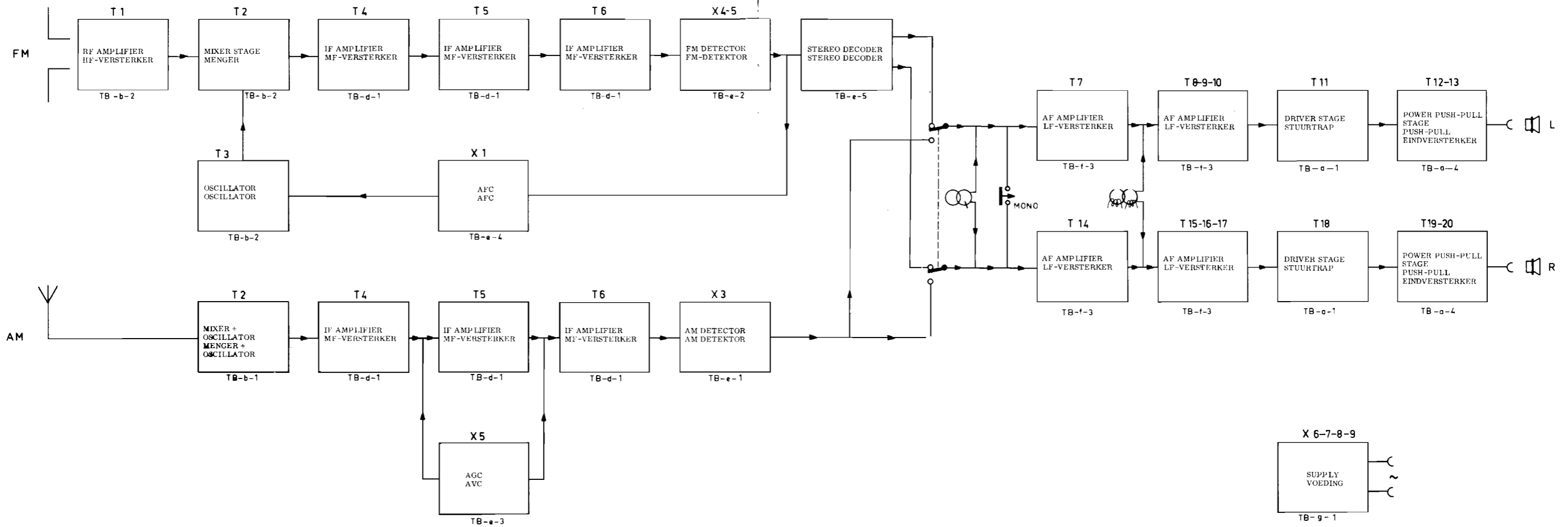

TRA 3104

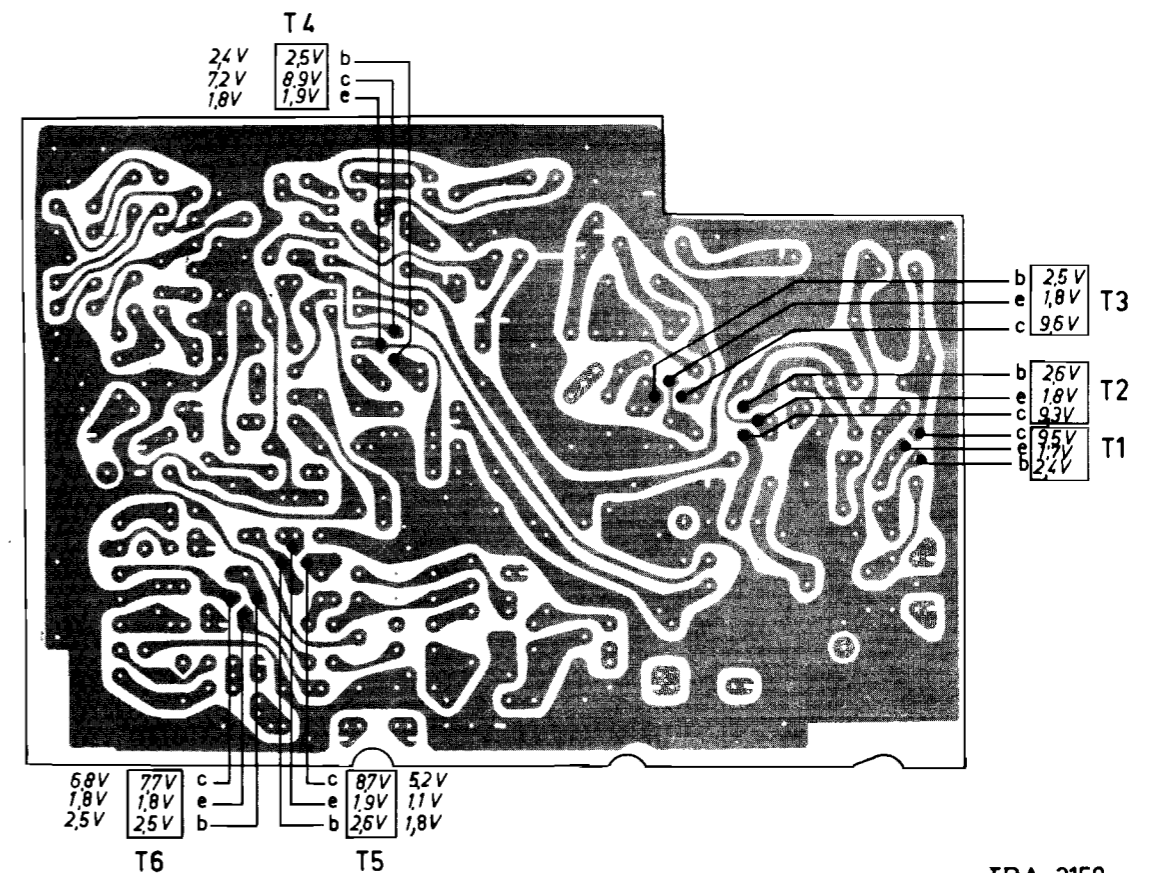
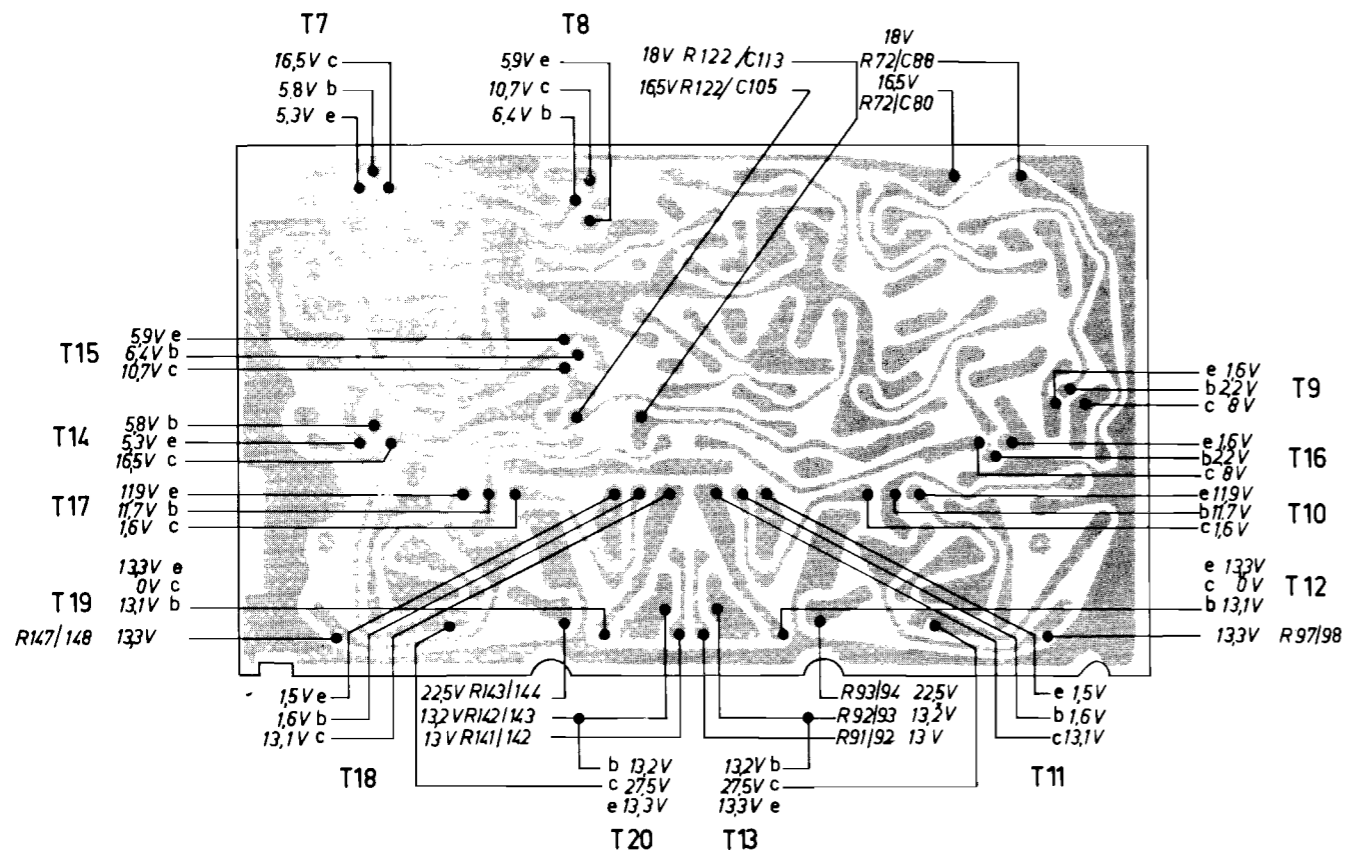

TRA 3158

1. Detune S20 and S21, 22.
2. Apply a signal to the aerial input via a dummy aerial. Aerial switch in the position where the ferroceptor is switched off.
3. Apply the signal to the ferroceptor via a coupler winding. Aerial switch in the position where the ferroceptor is switched on.
4. AFC switched off.
5. Unsolder capacitor C39 and detune S24, 25-S18, 19-S14, 15 and S44, 45, 46. Connect an oscilloscope between junction R24-R30 and chassis. Signal: frequency-modulated. Adjust so that the height and the symmetry of the band-pass curve are maximum.
6. Re-connect capacitor C39. Signal: frequency-modulated. Connect oscilloscope between junction R32-R34 and chassis. Adjust so that the symmetry of the S-curve is maximum. Connect valve voltmeter between junction R32-R34 and chassis. Adjust to 0 V.
7. Signal: FM+AM. Adjust for maximum AM rejection (if necessary, by means of S24, 25).
8. In view of oscillations, keep the connection wires of the generator as short as possible.

* The IF is 452 kHz for the 5911/03/04 and the 5912/03/04.

** Coil S50 (IF rejection coil) should be adjusted only in the 5911/03/04 and the 5912/03/04.

1. Ontregel S20 en S21, 22.
2. Signaal via kunstantenne aan de antenne-ingang toevoeren. Antenneschakelaar in stand "ferroceptor uitgeschakeld".
3. Signaal via koppelwinding aan de ferroceptor toevoeren. Antenne-schakelaar in stand "ferroceptor ingeschakeld".
4. AFC moet uitgeschakeld zijn.
5. Condensator C39 lossolderen en S24, 25-S18, 19-S14, 15 en S44, 45, 46 ontregelen. Oscillograaf aansluiten tussen knooppunt R24-R30 en chassis. Signaal FM-gemoduleerd. Afregelen op max. hoogte en symmetrie van de doorlaatkromme afregelen.
6. Condensator C39 vastmaken. Oscillator aansluiten tussen knooppunt R32-R34 en chassis en afregelen op symmetrie van de S-kromme. Buisvoltmeter aansluiten tussen knooppunt R32-R34 en chassis en afregelen op 0 V.
7. Signaal FM+AM gemoduleerd en afregelen op max. AM onderdrukking (eventueel met S24, 25).
8. Aansluitdraden van generator zo kort mogelijk houden, in verband met oscillatie.

* Voor de 5911/03/04 en de 5912/03/04 is de MF 452 kHz.

** Spoel S50 (MF-sperkringspoel) dient alléén in de 5911/03/04 en de 5912/03/04 afgeregeld te worden.

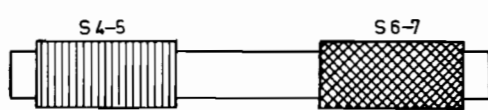
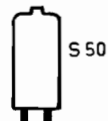
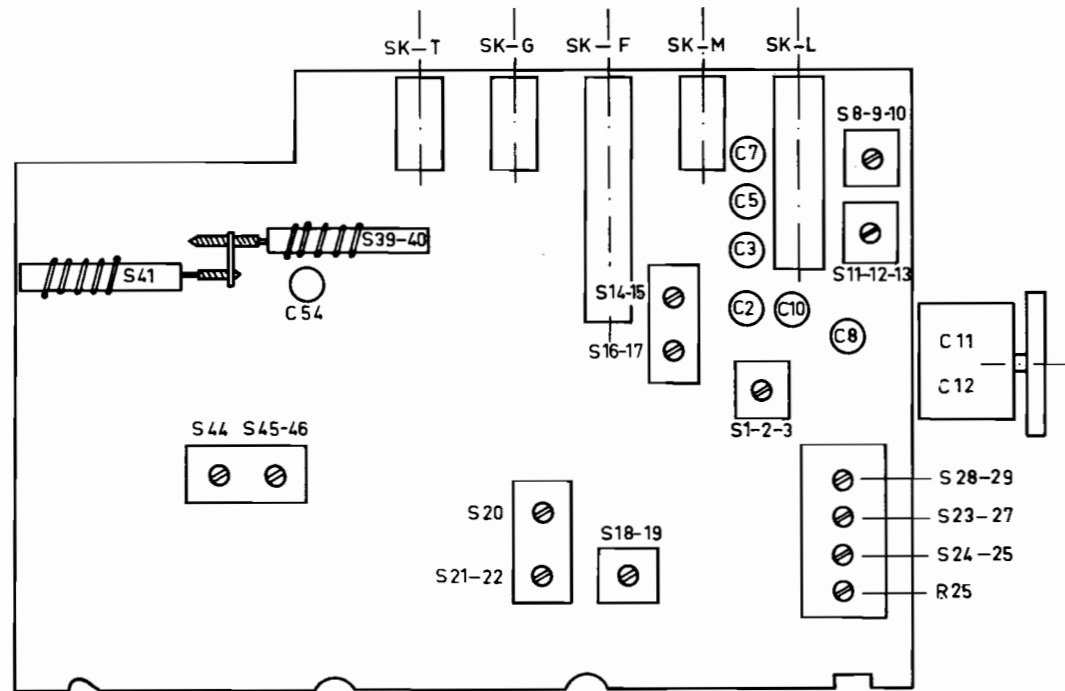

TRA 3105

Serv-o-mecum	Wave range Golfg gebied	Trimming point Trimpunt	Signal Signaal	Adjust Afgeregelen	Indication Aanwijzing		
TE-a-1 TE-a-2 TE-a-3							
IF - MF	MW - MG	B	* 470 kHz via 33 kpF 1)	b-T6 R14-R58 R5-R57 b-T4 S28, 29 S21, 22 S20 S16, 17 S50 **	max. min.		
Adjusting the pointer : stroke of the pointer = AD Instellen van de wijzer : slag van de wijzer = AD							
RF - HF	MW-MG	B	1500 kHz	3)	C8-C3	max.	
		C	560 kHz		S1, 2, 3-S4, 5		
	Repeat - Herhalen						
	LW-LG	C	160 kHz	3)	C10-S6, 7		
		B	268 kHz		C2		
	Repeat - Herhalen						
	LW-LG	B	268 kHz	Y 2)	C5		
		C	160 kHz		S11, 12, 13		
	Repeat - Herhalen						
	MW-MG	B	1500 kHz	Y 2)	C7		
		C	560 kHz		S8, 9, 10		
	Repeat - Herhalen						
IF - MF	FM 4)	100 MHz	10, 7 MHz via 1500 pF 10, 7 MHz via 1500 pF	b-T6	S23, 27	5)	
				b-T5	S18, 19		
				b-T4	S14, 15		
				e-T2 8)	S44-S45, 46		
					S24, 25		6)
R25	7)						
RF - HF	FM 4)	86, 5 MHz 94 MHz Repeat - Herhalen	86, 5 MHz 94 MHz	C54	max.		
				S39, 40-S41			

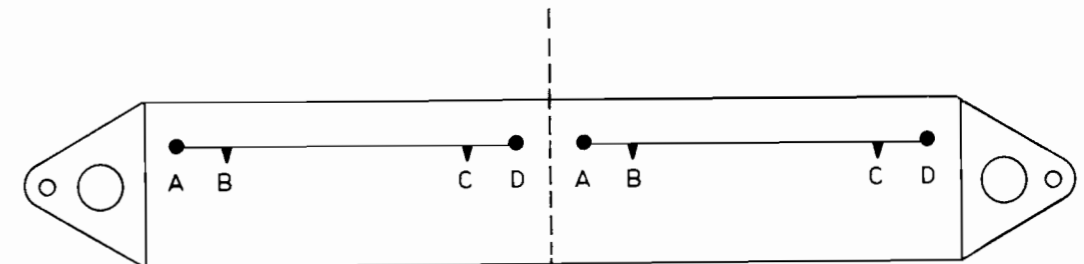

TRA 3139

STEREO DECODER

S	414										415										416									
C	500	501	502	503	504	505	506	507	508	509	510	511	512	513	514	515	516	517	518	519	520	521	522	523	524	525				
R	600	601	602	603	604	605	606	607	608	609	610	611	612	613	614	615	616	617	618	619	620	621	622	623	624	625				

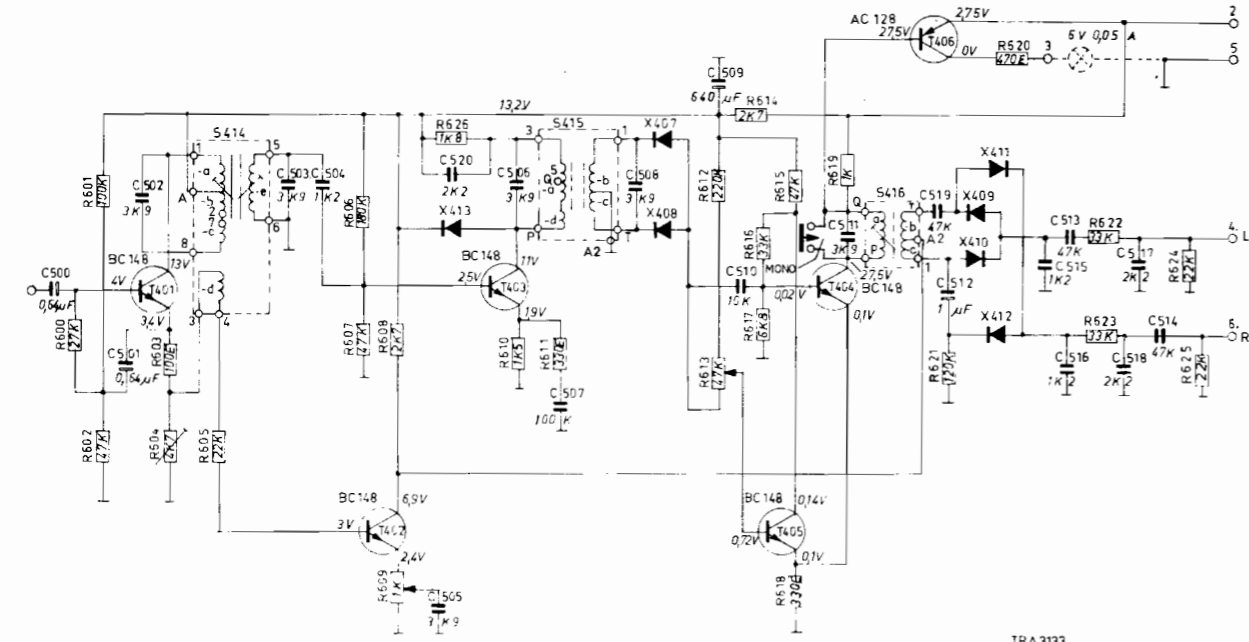

TRA 3133

- The voltages have been measured with respect to the chassis with the aid of a valve voltmeter. The voltages in squares have been measured in position FM.

- De spanningen zijn m.b.v. een buisvoltmeter t.o.v. chassis gemeten. De omlijnde spanningen zijn gemeten in stand FM.

S	416										415										414																			
C	518	516	514	509	513	519	515	512	517	511	500	501	505	510	508	502	520	504	506	503	507	623	624	619	612	616	615	617	613	618	609	604	608	605	606	626	607	610	611	
R	625	622	621	624	619	612	616	615	617	613	618	609	604	608	605	606	626	607	610	611	625	622	621	624	619	612	616	615	617	613	618	609	604	608	605	606	626	607	610	611

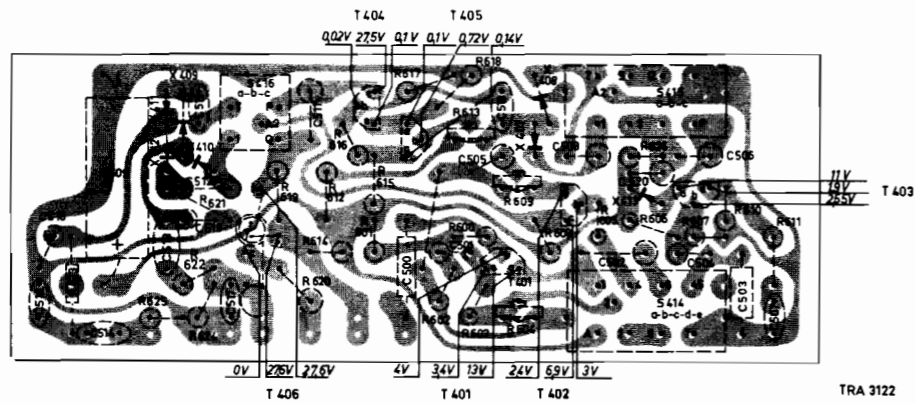

TRA 3122

S	414										415										416																				
C	507	503	506	504	520	502	508	510	505	501	500	511	517	512	515	519	513	509	514	516	518	611	610	607	526	606	605	508	604	609	618	613	617	615	616	612	619	624	621	623	
R	600	603	607	601	602	604	605	607	608	609	610	611	612	613	614	615	616	617	618	619	620	621	622	623	624	625	626	627	628	629	630	631	632	633	634	635	636	637	638	639	640

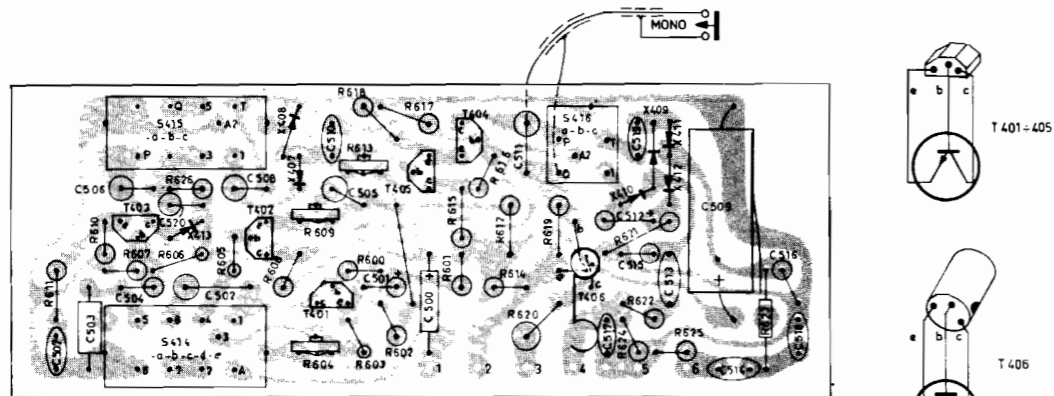

TRA 3121

STEREO DECODER

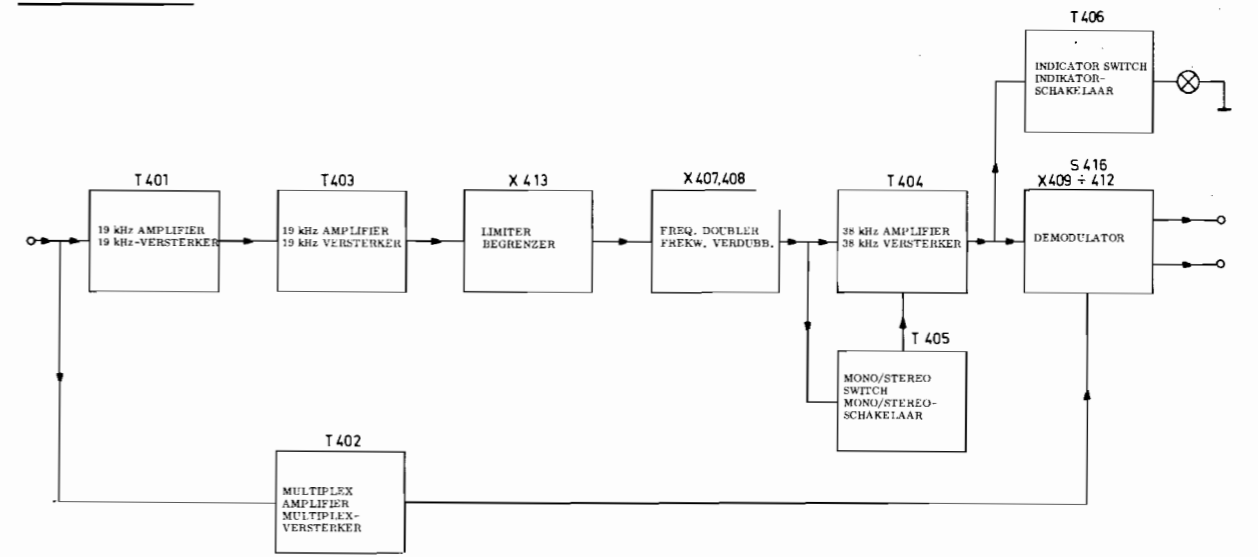

TRA 3118

DETECTION-UNIT

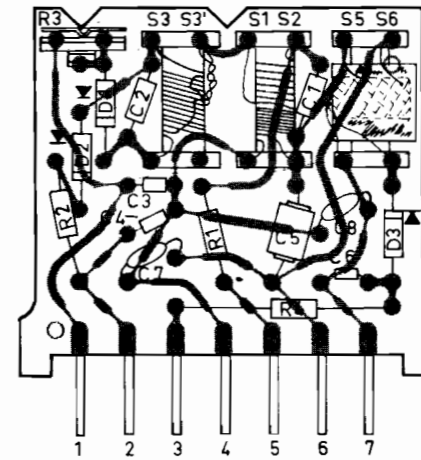

TRA 3143

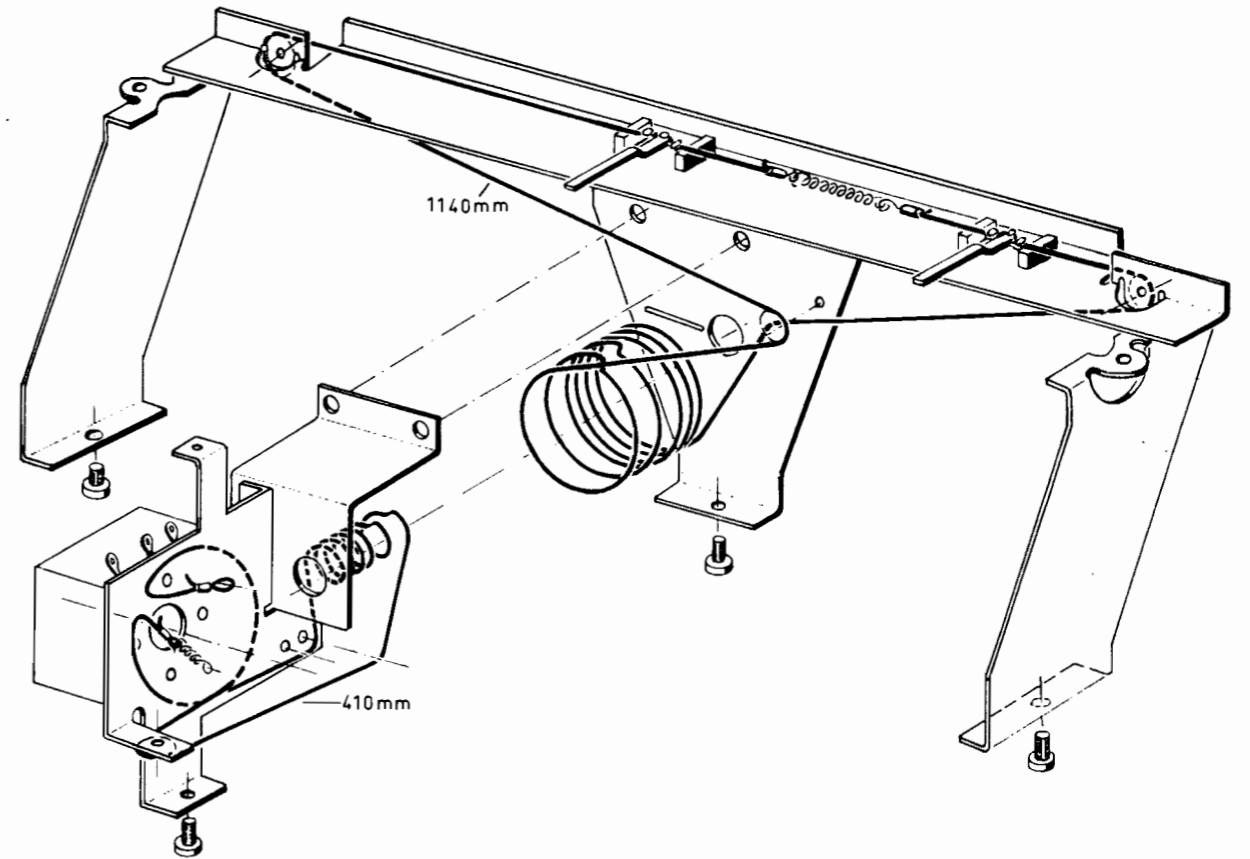

TRA 3159