

PHILIPS SERVICE

208 U-04-09-12

16,5-51 m (18,2-5,88 Mc/s) 9686 U-50 Z = 5 Ω
 196- 570 m (1530-522 kc/s)
 750-1910 m (400-157 kc/s) 110 V, 125 V, 220 V.

452 kc/s ±34 W.

	196-570 m	III		750-1910 m	III	
VOL.	max		VOL.	max		
	C6, C8 + 15°			1875 m (160 kc/s)		
	1500 kc/s — Y			160 kc/s — Y		
	C38 max			C50 max		
	C18 max					

15° 09 992 50.0

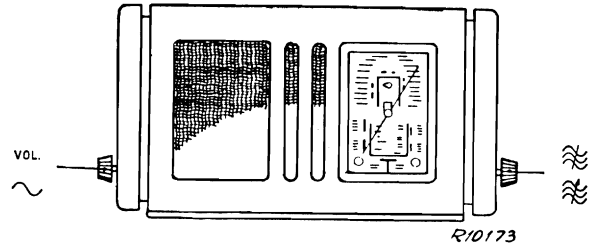

1943

R11	0,45 + 0,05M	49 500 23.0	C1	27 μF	49 021 03.0
R31	0,82 MΩ	48 557 10/820K	C2	2 × 2,5 μF	49 021 04.1
R32	10 KΩ	48 557 10/10K	C6	11-400 pF	A9 863 99.0
R33	68 KΩ	48 557 10/68K	C8	11-400 pF	
R34	1,5 MΩ	48 557 10/1M5	C14	10 pF	48 201 10/10E
R35	6,8 MΩ	48 557 10/6M8	C18	32 pF	49 005 51.2
R36	0,68 MΩ	48 557 10/680K	C19	39 pF	48 203 10/39E
R39	520 Ω		C20	12 pF	49 201 10/12E
R40	600 Ω		C38	32 pF	49 005 51.2
R44	75 Ω	49 362 90.2	C40	22 pF	49 201 05/22E
R45	580 Ω		C48	382,5 pF	48 203 01/382E5
R42	5600 Ω	48 557 10/5K6	C50	125 pF	49 005 52.2
R43	150 Ω	48 494 10/150E	C51	103 pF	—
R46	4700 Ω	48 557 10/4K7	C52	103 pF	—
R75	220Ω par	48 557 10/220E	C61	103 pF	—
	270Ω = 120Ω	48 557 10/270E	C62	103 pF	—
R81	47 KΩ	48 557 10/47K	C75	100 μF	48 313 22/100
R82	470 Ω	48 467 10/470E	C85	4700 pF	48 757 20/4K7
			C100	1000 pF	48 757 20/1K
			C101	100 pF	48 203 10/100E
			C102	470 pF	48 203 10/470E
			C103	47 pF	48 203 10/47E
			C104	47000 pF	48 751 10/47K
			C105	47000 pF	48 750 10/47K
			C106	6800 pF	48 751 10/6K8
			C107	100 pF	48 203 10/100E
			C108	68 pF	48 203 10/68E
			C110	22000 pF	48 758 20/22K
			C112	2,5 μF	49 021 04.1
			C120	0,1 μF	48 751 10/100K

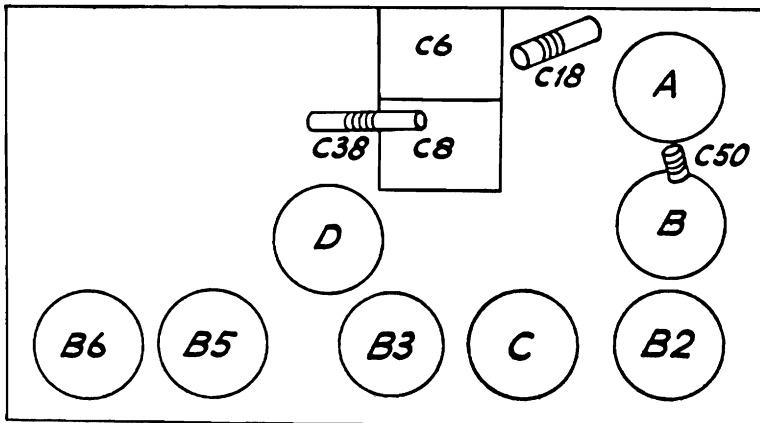

R14121

	B2	B3	B5	B6	
	UCH 21	UCH 21	UBL 21	UYIN	
V _a	aT = 80 aH = 110	aT = 25 aH = 110	105	—	V
V _{g2(4)}	70	70	115	—	V
V _k	0	0	0	—	V
I _a	aT = 2,8 aH = 1,3	aT = 1,3 aH = 1,9	35	—	mA
I _{g2(4)}	2,6	1,3	5,6	—	mA

VC1 = 145 V, VC2 = 115 V, VC3 = 120 V, VC75 = 6 V, VS71 = 30 V, IS71 = 54mA.

Copyright
 N.V. Philips Gloeilampenfabrieken, Eindhoven
 Imprimé en Hollande

93 953.12.

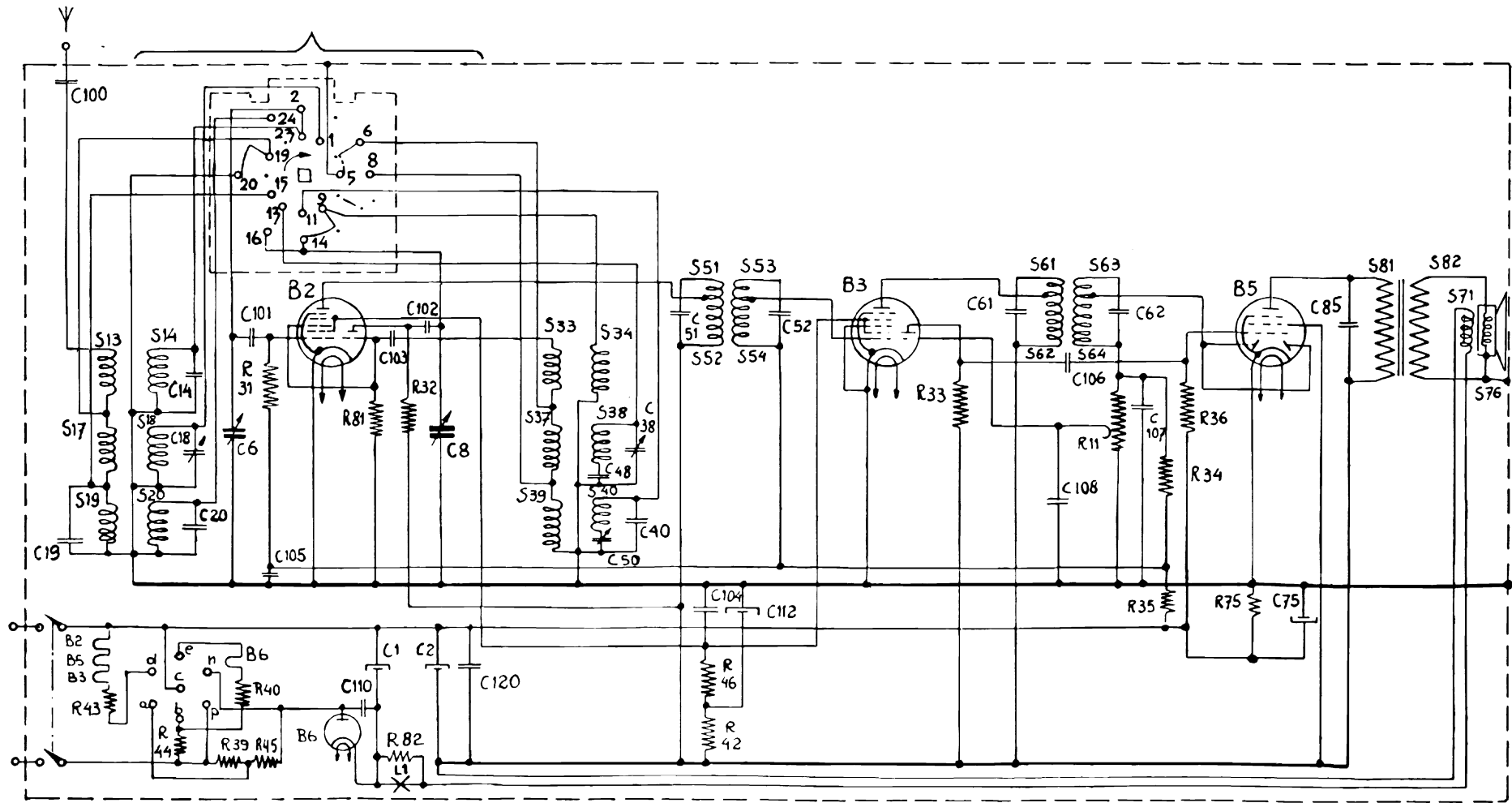

R 10154

UCH 21

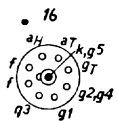

B 2

UCH 21

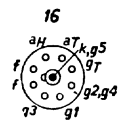

B 3

UBL 21

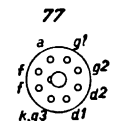

B 5

UYIN



B 6

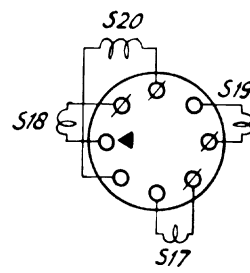

A

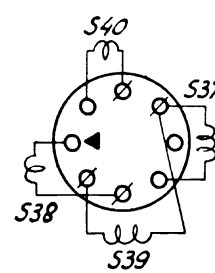

B

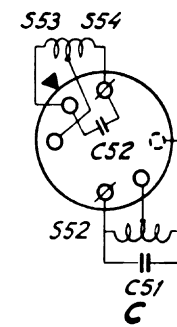

C

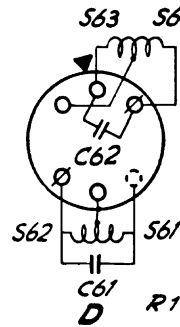

D

R 11891