

PHILIPS-SERVICE

461 U

16,7—51 m
198—585 m
720—2000 m

9656 Z=5 Ω
110—220 V (238—265 mA)

128 kc/s
118 kc/s (U-29, -32)

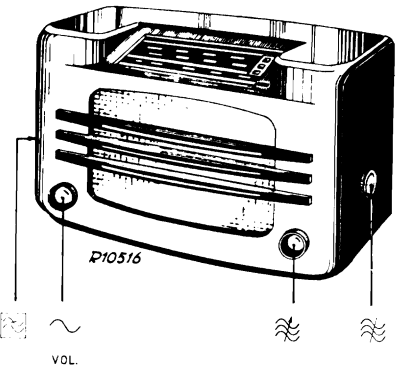

720—2000 m I	720—2000 m II	720—2000 m III
VOL. max 128 kc/s-33000 pF-g1B2 118 kc/s (U-29, -32) C26, C25 max 128 kc/s-33000 pF-g4B1 118 kc/s (U-29, -32) C21, C22 max	VOL. max C4, C5, C6 2000 m 128 kc/s— 118 kc/s (U-29, -32) C37 min 198—585 m III C4, C5, C6 + 15° VOL. max 1442 kc/s— C12, C7, C8 max	C4, C5, C6 + 15° VOL. max 414 kc/s— C9 max 198—585 m V 810 kc/s— C4, C5, C6 810 kc/s 370 m

15° 09 992 44.0

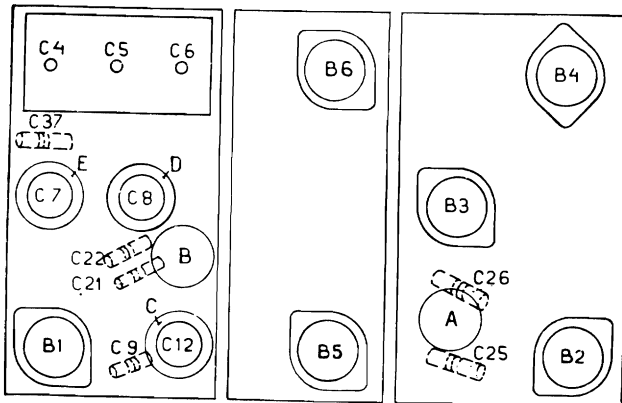

R12726A

220 V ~

	B1	B2	B3	B4	B5	B6	
	CK1	CF3	CBC1	CL4 CL2 ¹⁾	CY1	C8 (220) C9 (130)	
Va	208	210	90	200			V
Vg2	77	77	—	203			V
Vg 3-5	77	—	—	—			V
—Vg	2,2	2,2	2,3	9			V
Ia	1,4	6,8	1,2	44			mA
Ig2	2	2,6	—	4,7			mA
Ig 3+5	4,2	—	—	—			mA

VC¹ = 220 V

VC² = 212 V

Copyright
N.V. Philips' Gloeilampenfabrieken, Eindhoven
Imprimé en Hollande

¹⁾ U-29
²⁾ U-32
³⁾ U-20
⁴⁾ U-04

R1	3900 Ω	48 426 10 3K9	C1	25 μF	48 312 09/25
R2	47 Ω	48 425 10 47E	C2	25 μF	48 312 09/25
R3	0,1 MΩ	48 425 10 100K	C3	50 pF	48 313 02 50
R4	47000 Ω	48 425 10 47K	C4	11-490 pF	28 212 193
R5	18000 Ω	28 803 520*	C5	11-490 pF	
R6	3300 Ω ¹⁾	48 552 10 3K3	C6	11-490 pF	23 212 17.0* ³⁾
R7	0,1 MΩ	48 425 10 100K	C7	11-490 pF	
R8	270 Ω	48 425 10 270E	C8	11-490 pF	28 212 06.2
R9	0,27 MΩ	48 425 10 270K	C9	11-490 pF	
R10	47000 Ω ¹⁾	48 425 10 47K	C10	32 pF	48 406 10 22E
R11	0,35 MΩ	49 500 55	C11	22 pF	48 406 10 47E
R12	1,5 MΩ	43 426 10 1M5	C12	47 pF	48 429 10 70E
R13	2200 Ω	48 425 10 2K2	C13	70 pF	48 429 10 80E
R14	2700 Ω	48 425 10 2K7	C14	80 pF	48 429 10 80E ¹⁾²⁾
R15	15000 Ω ¹⁾	48 425 10 15K	C15	15000 pF	48 751 10 15K
R16	1,5 MΩ	45 426 10 1M5	C16	39000 pF	48 751 10 39K
R17	5600 Ω	48 425 10 5K6	C17	47000 pF	48 751 10 47K
R18	18000 Ω ¹⁾	48 425 10 18K	C18	2 pF	28 205 88.0
R19	0,47 MΩ	48 425 10 470K	C19	1425 pF	48 429 02 1K425
R20	0,1 MΩ	48 425 10 100K	C20	1536 pF	48 429 02 1K536
R21	0,82 MΩ	48 425 10 820K	C21	770 pF	48 429 02 770E
R22	1000 Ω	48 425 10 1K	C22	758 pF	48 429 02 758E
R23	220 Ω ¹⁾	48 425 10 220E	C23	0,1 μF	48 751 10 100K
R24	180 Ω	43 426 10 180E	C24	32 pF	28 212 06.2
R25	0,82 MΩ	48 425 10 820K	C25	32 pF	48 406 10 33E
R26	50000 Ω	28 812 50.1	C26	33 pF	48 406 10 100E
R27	330 Ω	48 425 10 330E	C27	100 pF	48 751 10 10K
	100 Ω	48 425 10 100E	C28	10000 pF	48 751 10 10K
	120 Ω	48 468 10 120E	C29	32 pF	48 429 10 32E
	8200 Ω ¹⁾	48 469 10 8K2	C30	50 pF	48 429 10 50E
	0,12 MΩ ¹⁾	48 426 10 120K	C31	40 pF	48 429 10 40E
			C32	68 pF	48 406 10 68E
			C33	50 pF	43 429 10 50E
			C34	68 pF	48 406 10 68E
			C35	68 pF	48 406 10 68E
			C36	90 pF	48 429 10 90E
			C37	32 pF	28 212 06.2
			C38	250 pF	48 429 10 250E
			C39	47000 pF	48 757 20 47K
			C40	0,1 μF	48 757 20 100K
			C41	2200 pF	48 751 10 2K2
			C42	100 pF	48 406 10 100E
			C43	0,1 μF	48 751 10 100K
			C44	22000 pF	48 751 10 22K
			C45	4700 pF	48 751 20 4K7
			C46	4700 pF	48 751 20 4K7
			C47	20 pF	48 406 99 20E
			C48	4700 pF	48 751 20 4K7
			C49	25 μF	48 317 09 25
			C50	25 μF	48 317 09 25 ¹⁾²⁾
			C51	25 μF	48 312 09 25
			C52	25 μF	48 312 09 25
			C53	47000 pF	48 750 20 47K ⁴⁾

S5	28 587 88.0	S20, S21	28 571 77.2*
S6, S7, S8, S9, C7	28 571 59.2	S22, S23, S23a	28 571 78.0
S10, S11, S12, S13, C8	28 571 79.3	S24, S25	28 534 22.0
S14, S15, S16, S17, S18, S19, C12	28 571 80.3*	S26	28 535 51.0 ¹⁾
	28 572 27.1*	S27, S28	28 220 51.1
		S29, S30	28 587 69.0
		S31	28 587 06.1
			28 546 08.1

93 952 09.1

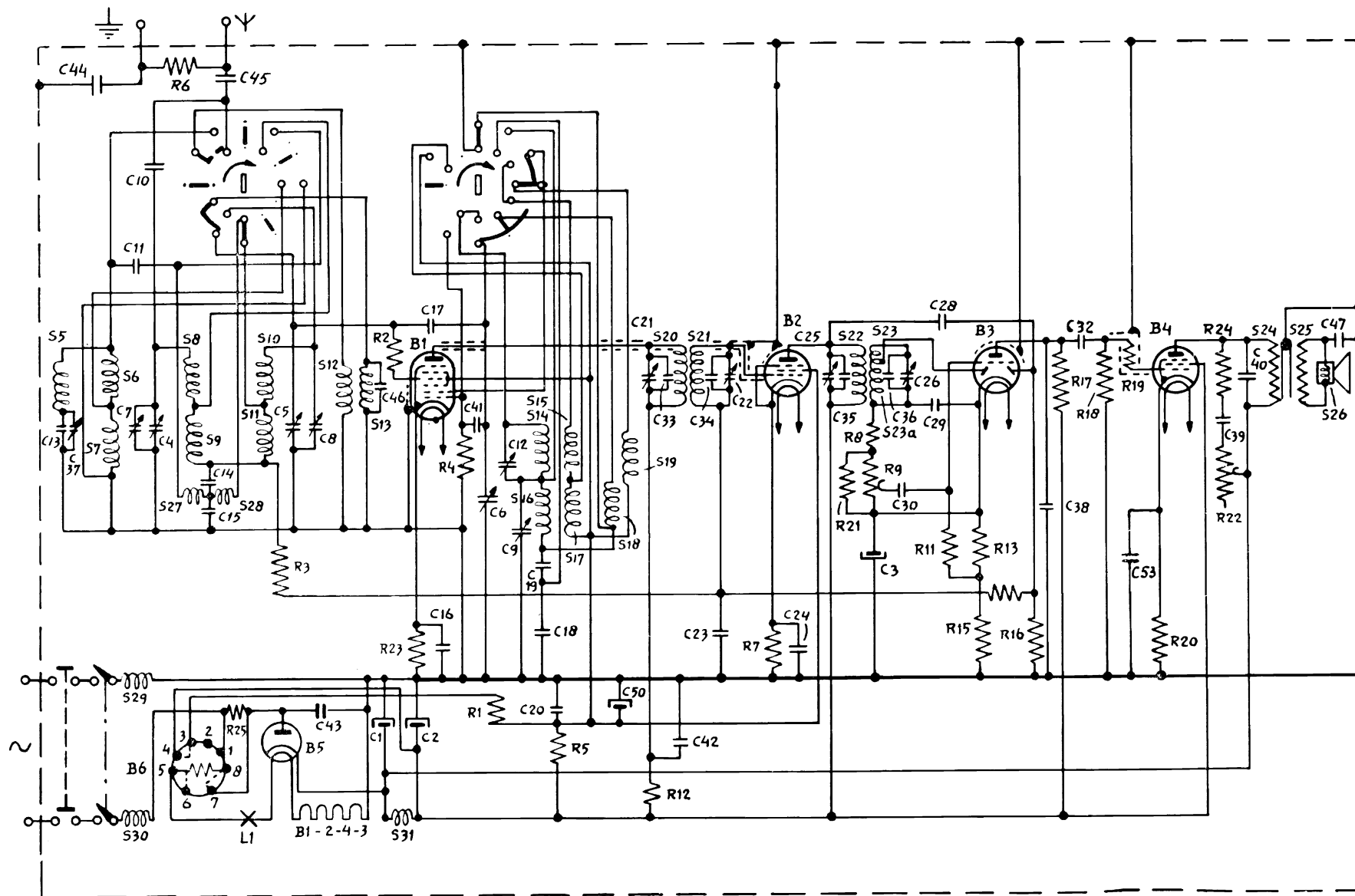

R12064

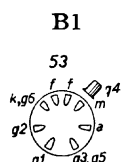

CK1

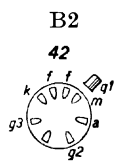

CF3

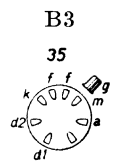

CBC1

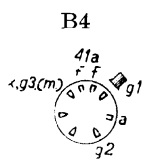

CL4, CL2

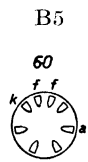

CY1



C8

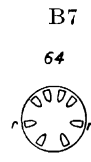

C9

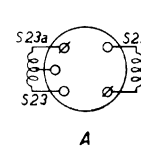

A

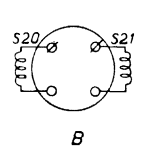

B

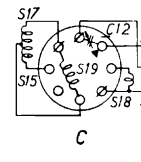

C

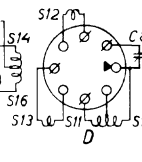

D

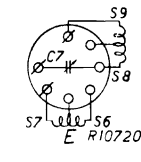

E

R10720A