

PHILIPS-SERVICE

628 B

\approx 16,5—51 m
 (B-32) 100—200 m
 198—585 m
 720—2000 m
 (B-13) 708—2000 m

 128 kc/s
 B-32 118 kc/s
 B-48

\square 9614 Z = 5 Ω

 \square 2 V, 144 V
 If = 0,43 A
 Ia = 12 mA

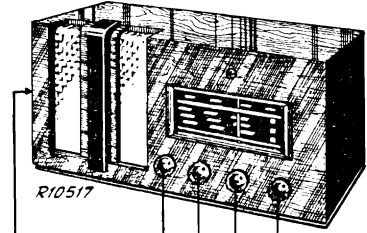

720—2000 m I	198—585 m III	198—585 m IV
VOL max. 128 kc/s-33000 pF-g4 B, 118 kc/s (B-32, B-48) S16—25000 Ω C25, C26, C21 max. S16 S17—25000 Ω C20 max. S17	C1, C2, C3 + 15° max. 1442 kc/s—Y C15, C6, C11 max.	968 kc/s—Y C1, C2, C3 \pm 400 m. C7 min.
720—2000 m II	720—2000 m III	198—585 m V
C1, C2, C3 max max. 128 kc/s—Y 118 kc/s (B-32, B-48) C4 min.	C1, C2, C3 + 15° max. 395 kc/s—Y C16 max.	320 m—Y C1, C2, C3 \pm 320 m. 320 m

15° = 09.9 92 44.0

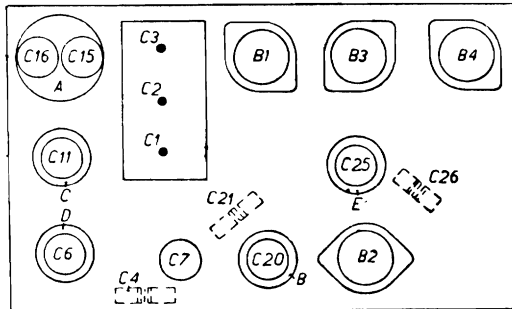

R10924

	B1 = KK2		B2 = KF4		B4 = KL4		B3
	R1, R20	R1, R20	R1, R20	R1, R20	R1, R20	R1, R20	
Va	135	135	74	58	125	131	V
Vg2	131	132	89	78	135	135	V
Vg3(5)	50	27	—	—	—	—	V
Vg4	+1	+1	—	—	—	—	V
Vg	—	—	1,4	0,65	5,1	7,7	V
Ia	1	0,22	0,59	0,76	6,1	2,1	mA
Ig2	2	1,6	0,21	0,27	1,1	0,35	mA
Ig3(5)	0,9	0,31	—	—	—	—	mA

R1	1000 Ω	48 426 10/1K	C1	11-490 pF)	
R2	0,1 M Ω	48 426 10/100K	C2	11-490 pF)	28 212 19.0
R3	47000 Ω	48 426 10/47K	C3	11-490 pF)	
R4	68000 Ω	48 426 10/68K	C4	125 pF	28 212 07.2
R5	33000 Ω	48 426 10/33K	C5	22 pF	48 406 10,22E
R6	0,68 M Ω	48 425 10/680K	C6	3—30 pF	
R7	1,5 M Ω	48 426 10/1M5	C7	3—30 pF	
R8	0,22 M Ω	48 426 10/220K	C8	27 pF	48 406 10/27E
R9	47000 Ω	48 426 10/47K	C9	15000 pF	48 751 10/15K
R10	0,5 M Ω	28 814 810	C10	27000 pF	48 751 10/27K
R11	0,1 M Ω	48 426 10/100K	C11	3—30 pF	
R12	1 M Ω	48 426 10/1M	C12	12 pF	48 406 10/12E
R13	0,3 M Ω	28 812 580	C12 ¹⁾	32 pF	48 429 10/32E
R14	0,3 M Ω		C13	0,1 μ F	48 751 10/100K
R15	120 Ω	48 426 10/120E	C14	100 pF	48 406 10/100E
R16	330 Ω	48 426 10/330E	C15	3—30 pF	
R17	0,1 M Ω	48 426 10/100K	C16	3—39 pF	
R18	2,2 M Ω	48 427 10/2M2	C17	772 pF	48 429 01/772E
R19	390 Ω	48 426 10/390E	C17 ¹⁾	800 pF	48 429 01/800E
R20	0,27 M Ω	48 426 10/270K	C18	1460 pF	48 429 01/1K46
R21	47 Ω	48 425 10/47E	C18 ¹⁾	1550 pF	48 429 01/1K55
R22	2200 Ω	48 426 10/2K2	C19	10 pF	48 406 99/10E
R23	22 Ω	48 425 10/22E	C19 ¹⁾	32 pF	48 429 10/32E
R30	470 Ω	48 426 10/470E	C20	12-170 pF	
			C21	125 pF	28 212 07.2
			C22	27 pF	48 406 10/27E
			C23	10000 pF	48 751 10/10K
			C24	0,1 μ F	48 751 10/100K
			C25	12-170 pF	
			C26	125 pF	28 212 07.2
			C27	39 pF	48 406 10/39E
			C28	10000 pF	48 751 10/10K
			C29	220 pF	48 406 10/220E
			C30	400 pF	48 429 10/400E
			C31	400 pF	48 429 10/400E
			C32	1000 pF	48 752 20/1K
			C33	8 μ F	28 182 90.0
			C34	68 pF	48 406 10/68E
			C35	125 pF	48 429 10/125E
			C36	0,27 μ F	48 751 10/270K
			C37	47000 pF	48 751 10/47K
			C38	100 pF	48 429 10/100E
			C39	50 μ F	49 020 01.0
			C40 ¹⁾	2700 pF	48 429 01/2K7

S1	28 587 88.0	S14, S15	28 587 96.0
S2, S3, S4, S5, C6	28 570 54.1	S14, S15	28 588 32.1 ¹⁾
S6, S7, C11	28 570 49.1	S16, S17, C20	28 572 60.1
S8, S9	28 588 27.0	S18, S19, C25	28 570 72.0
S8, S9	28 583 311 ¹⁾	S20, S21	28 537 03.0
S10, S11, S12, S13	28 573 56.0	S22	28 220 43.1
C15, C16			

S:	1, 2, 4, 3, 5,	6, 7,	8, 9,	10, 11, 12, 13, 14, 15,	16, 17,	18, 19,	20, 21, 22,		
C:	34, 4, 39, 5, 6, 7, 8, 1,	9, 10,	11,	37, 12, 2,	13, 14, 3, 15, 16, 17, 18,	19,	20, 21, 22, 35, 23, 24,	27, 26, 25, 28, 29, 38, 30, 31,	32, 33, 36,
R:	19, 13, 16, 1,	2,	21, 3,	22, 4, 5, 20,	6, 7,	8,	18, 9, 10, 11,	12, 13, 14, 17,	

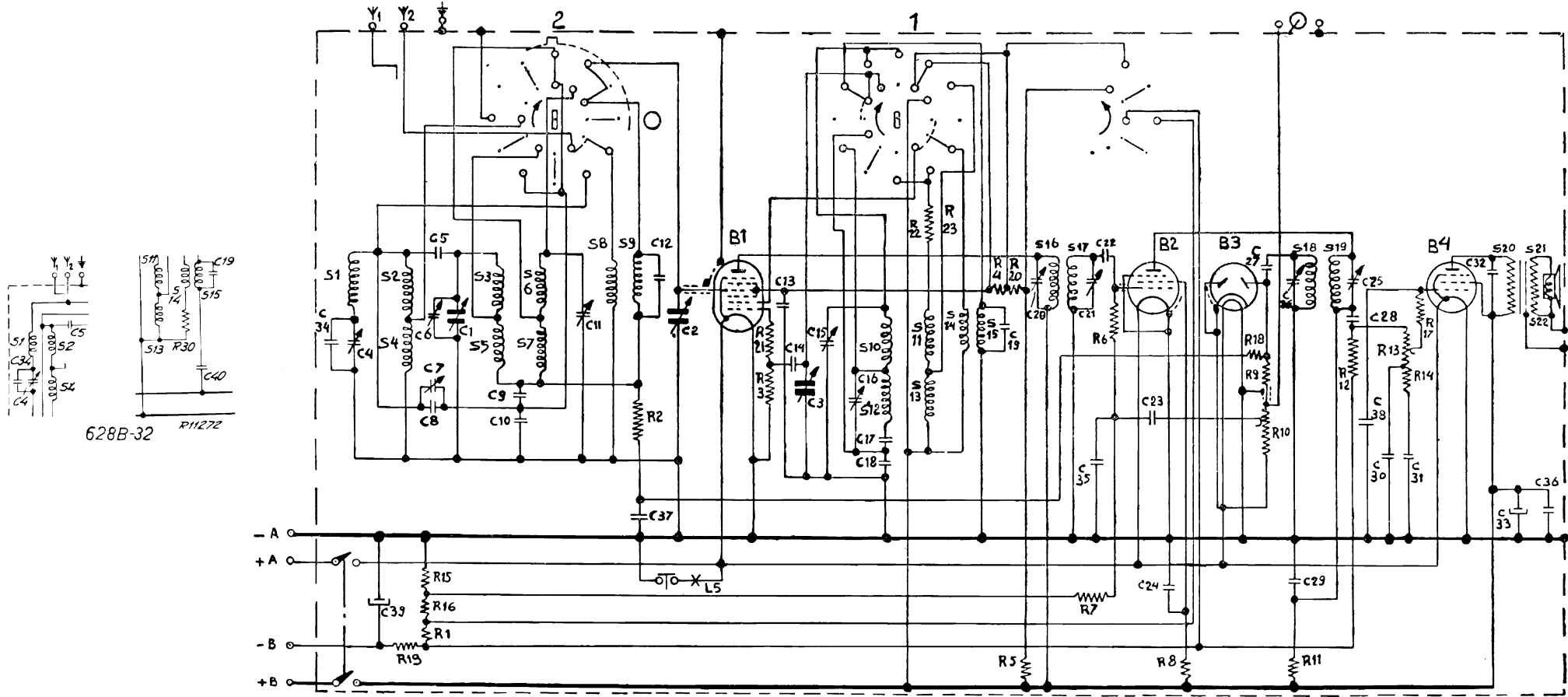

628B-32 R11272

R11198

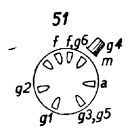

B1

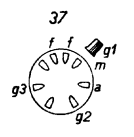

B2

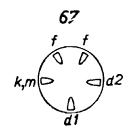

B3

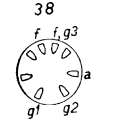

B4

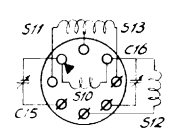

A

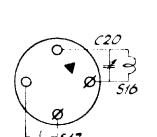

B

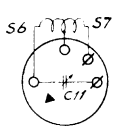

C

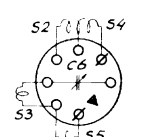

D

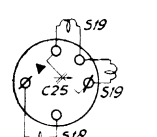

E

R10521A