

PHILIPS SERVICE

BX 281 U-00-03-04-06-20

16,5— 51 m (18,2— 5,9 Mc/s)
 185 — 580 m (1620 —517 kc/s)
 750 —1910 m (400 —157 kc/s)
 452 kc/s
 468 kc/s (—U06)

9712-06 Z = 5 Ω
 9730 Z = 5 Ω
 110, 200 V, R37: 125, 220 V
 125, 220 V, R37: 110, 200 V
 40 W

	16,5—51 m III		185—580 m III		185—580 m V
	min		max		1153 kc/s— Y
	-25 pF—aB2		C6, C8 +15°		C6, C8 1153 kc/s
	C8		1550 kc/s— Y		260 m
	15,2 Mc/s— Y		C38 max		750—1910 m V
	C6, C8 15,2 Mc/s		C18 max		1875 m
	max		750—1910 m III		160 kc/s— Y
	C8		min		C50 max
	C6, C8 15,2 Mc/s		-25 pF —aB2		
	C34 max		C8		
			160 kc/s— Y		
			C6, C8 160 kc/s		
			max		
			C8		
			C50 max		

15° A9 600 18.0

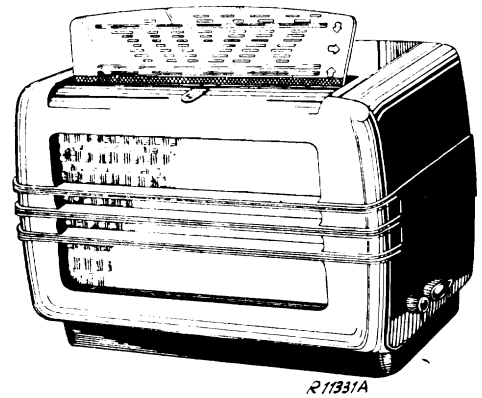

1948

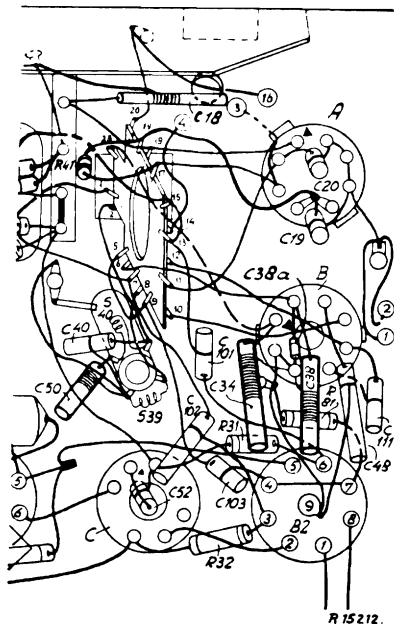

R 1	1200 Ω	48 494 10/1K2	C1	50 + 50 μF	4831708/50 + 50
R11	0,5 MΩ	49 500 11.0	C2		
R12	47 kΩ	48 555 10/47K	C6	11-400 pF	A9 863 99.0
R30		49 379 62.0	C8		
R31	0,82 MΩ	48 555 10/820K	C18	3,5-50 pF	49 005 50.2
R32	10 kΩ	48 556 10/10K	C19	39 pF	48 203 10/39E
R33	68 kΩ	48 426 10/68K	C20	22 pF	48 201 05/22E
R34	1 MΩ	48 556 10/1M	C34	7 pF	49 005 48.2
R35	6,8 MΩ	48 427 10/6M8	C38	7,5-100 pF	49 005 51.2
R36	0,68 MΩ	48 555 10/680K	C38a	(-U06)	
R37	75 Ω			8,2 pF	+8 201 20/8E2
R38	150 Ω	49 362 99.1	C40	49 pF	48 203 02/49E
R39	190 Ω		C48	421 pF	48 203 01/421E
R44		49 379 67.1	C50	20-275 pF	49 005 53.2
R40	10 kΩ	48 427 10/10K	C51		
R41	18 kΩ	48 555 10/18K	C52		
R43	6,8 MΩ	48 427 10/6M8	C61		
R75	220 + 270 Ω par	48 427 10/220E	C62		
R81	47 kΩ	48 557 10/270E	C75	100 μF	48 313 22/100
		48 555 10/47K	C83	6800 pF	48 751 10/6K8
			C85	4700 pF	48 758 20/4K7
			C100	1000 pF	48 757 20/1K
			C101	120 pF	48 203 10/120E
			C102	470 pF	48 203 20/470E
			C103	82 pF	48 203 10/82E
			C104	47000 pF	48 751 10/47K
			C105	47000 pF	48 750 10/47K
			C107	100 pF	48 203 20/100E
			C108	68 pF	48 203 20/68E
			C109	150 pF	48 203 10/150E
			C110	47000 pF	48 752 10/47K
			C111	56 pF	48 203 10/56E
			C112	1000 pF	48 757 20/1K
			C113	22000 pF	48 750 10/22K
			C130	12 pF	48 201 10/12E
Z1	300 mA	08 100 96.2			

	B2	B3	B5	
	UCH 21	UCH 21	UBL 21	
Va	aH = 135 aT = 95	aH = 135 aT = 30	150	V
Vg2(+4)	70	70	135	V
Ia	aH = 1,5 aT = 3,3	aH = 4,5 aT = 1,6	42	mA
Ig2(+4)	4,5	3	7,5	mA

VC1 = 165 V, VC2 = 135 V,

VC75 = 8,2 V

S17, S18, S19, S20 S13, S14, S33, S34, S37, S38, S100 S39, S40 S51, S52, S53, S54, C51, C52	A3 120 18.0 A3 120 17.3 A3 110 04.0 A3 121 03.3	S61, S62, S63, S64, C61, C62 S76 S81, S82	A3 123 23.1 49 981 13.1 A1 081 82.0
---	--	--	---

93 953 26.1

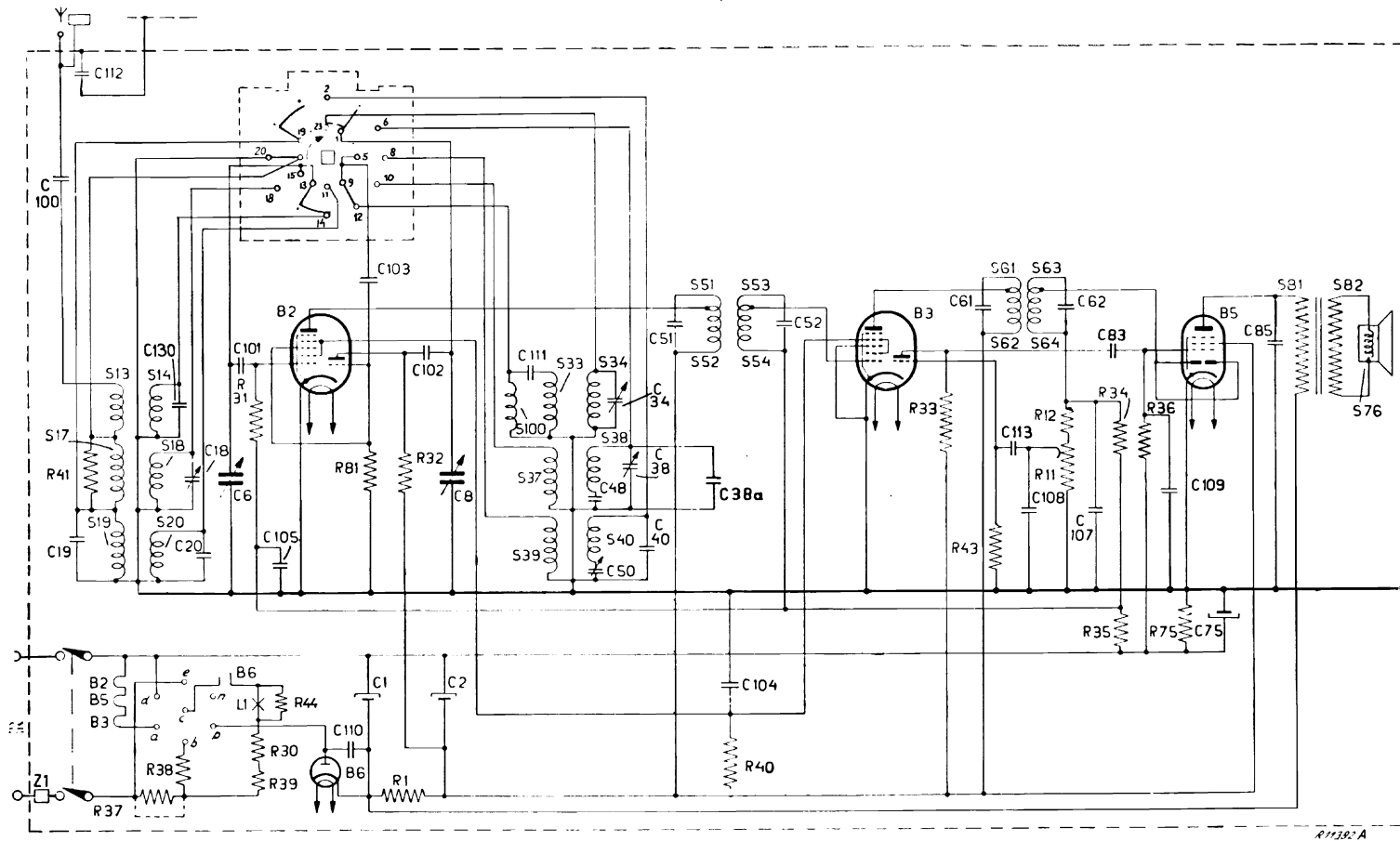

R1138: A

UCH 21

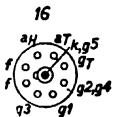

B1

UCH 21

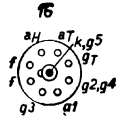

B2

UBL 21

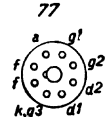

B3

UYIN



B4

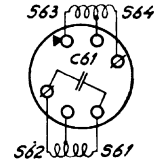
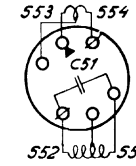
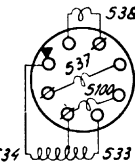
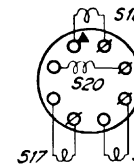

R10507A